

HAM INTERNATIONAL PVBA
BRUSSELSE STEENWEG, 428
B-9218 G E N T BELGIUM
☎ TEL. : 00-32-91-31 21 11
T E L E X : 12521 HAM B

SERVICE MANUAL

MULTIMODE 3

CONCORDE 3

JUMBO 3



HAM INTERNATIONAL

APRIL 1983

Channel-to-Frequency Chart

MHz		MHz		MHz		MHz		MHz	
Channel	Frequency	Channel	Frequency	Channel	Frequency	Channel	Frequency	Channel	Frequency
-80	26.065	-40	26.515	1	26.965	41	27.415	1	27.865
-79	26.075	-39	26.525	2	26.975	42	27.425	2	27.875
-78	26.085	-38	26.535	3	26.985	43	27.435	3	27.885
-77	26.095	-37	26.545	4	27.005	44	27.455	4	27.905
-76	26.105	-36	26.555	5	27.015	45	27.465	5	27.915
-75	26.115	-35	26.565	6	27.025	46	27.475	6	27.925
-74	26.125	-34	26.575	7	27.035	47	27.485	7	27.935
-73	26.135	-33	26.585	8	27.055	48	27.505	8	27.955
-72	26.145	-32	26.595	9	27.065	49	27.515	9	27.965
-71	26.155	-31	26.605	10	27.075	50	27.525	10	27.975
-70	26.165	-30	26.615	11	27.085	51	27.535	11	27.985
-69	26.175	-29	26.625	12	27.105	52	27.555	12	28.005
-68	26.185	-28	26.635	13	27.115	53	27.565	13	28.015
-67	26.195	-27	26.645	14	27.125	54	27.575	14	28.025
-66	26.205	-26	26.655	15	27.135	55	27.585	15	28.035
-65	26.225	-25	26.675	16	27.155	56	27.605	16	28.055
-64	26.235	-24	26.685	17	27.165	57	27.615	17	28.065
-63	26.215	-23	26.665	18	27.175	58	27.625	18	28.075
-62	26.245	-22	26.695	19	27.185	59	27.635	19	28.085
-61	26.255	-21	26.705	20	27.205	60	27.655	20	28.105
-60	26.265	-20	26.715	21	27.215	61	27.665	21	28.115
-59	26.285	-19	26.735	22	27.225	62	27.675	22	28.125
-58	26.295	-18	26.745	23	27.255	63	27.705	23	28.155
-57	26.305	-17	26.755	24	27.235	64	27.685	24	28.135
-56	26.315	-16	26.765	25	27.245	65	27.695	25	28.145
-55	26.335	-15	26.785	26	27.265	66	27.715	26	28.165
-54	26.345	-14	26.795	27	27.275	67	27.725	27	28.175
-53	26.355	-13	26.805	28	27.285	68	27.735	28	28.185
-52	26.365	-12	26.815	29	27.295	69	27.745	29	28.195
-51	26.385	-11	26.835	30	27.305	70	27.755	30	28.205
-50	26.395	-10	26.845	31	27.315	71	27.765	31	28.215
-49	26.405	-9	26.855	32	27.325	72	27.775	32	28.225
-48	26.415	-8	26.865	33	27.335	73	27.785	33	28.235
-47	26.435	-7	26.885	34	27.345	74	27.795	34	28.245
-46	26.445	-6	26.895	35	27.355	75	27.805	35	28.255
-45	26.455	-5	26.905	36	27.365	76	27.815	36	28.265
-44	26.465	-4	26.915	37	27.375	77	27.825	37	28.275
-43	26.485	-3	26.935	38	27.385	78	27.835	38	28.285
-42	26.495	-2	26.945	39	27.395	79	27.845	39	28.295
-41	26.505	-1	26.955	40	27.405	80	27.855	40	28.305

CONCORDE II

SPECIFICATIONS

GENERAL:

Frequency Composition: Digital phase-locked loop synthesizer
 Channels: 120 (80 + 40)
 Operating Mode: AM, FM, LSB, USB, CW
 Power Source: 13.8V DC (negative or positive ground)
 Antenna Impedance: 50 Ohm (SO-239 receptacle)
 Dimensions: 195-65-275 (width-height-depth mm)
 Weight: 3.15 kgs

RECEIVER:

Conversion System: AM/FM: Dual conversion superheterodyne
 SSB: Single conversion
 Sensitivity: AM: 0.7 μ V for 10 dB S/N
 FM: 0.5 μ V for 20 dB S/N
 SSB: 0.2 μ V for 10 dB S/N
 Selectivity: AM/FM: 6 kHz at 6 dB down
 SSB: 2 kHz at 6 dB down

Clarifier Range: \pm 4.5 kHz
 Tune Range: \pm 4.5 kHz minimum
 Audio Output: 3.5W to 8 Ohm, 10% THD
 Squelch Range: 0.7 to 300 μ V (all modes)

TRANSMITTER:

RF Power Output: AM: 4W/0.5W - FM: 4W/0.5W
 SSB: 12 Watt (PEP)
 AM Modulation Level: 100%
 FM Deviation: 1.5 kHz at 1250 Hz and 20 mV audio
 SSB Generation: Double balanced modulator with crystal lattice filter
 Carrier Suppression: 40 dB down
 Unwanted Sideband Suppression: 60 dB down
 Harmonic and Spurious Suppression: 60 dB down

MULTIMODE 3

SPECIFICATIONS - CARACTERISTIQUES - KENMERKEN

GENERAL - ALGEMEEN

Channels - Canaux - Kanalen: 200
 Operation mode: AM, FM, USB, LSB
 Power - Aliment. - Voeding: 13.8 VDC
 Freq.: 26.065 - 28.305 MHz
 Other bands for commercial and amateur use available. Livrable avec fréquences amateur ou commerciale. Leverbaar met amateur of commerciële frequenties.
 Ant. impedance: 50 Ohms
 Dimensions - Afmetingen: 190 x 63 x 215 mm
 Weight - Poids - Gewicht: 1,750 kg.

TRANSMITTER - EMETTEUR - ZENDER

RF Power output - Puiss. de sortie HF - HF uitgangsvermogen: AM, FM: 4 W - 0.5 W
 SSB: 12 W - 1 W (PEP)
 Freq. tolerance: < 0.005 %
 Modulation - Modulatie: 100 % AM - 1.5 kHz FM (limited)

RECEIVER - RECEPTEUR - ONTVANGER

Receiving system - Syst. de réception - Ontvangstysyst.: AM/FM dual conversion superheterodyne
 SSB: single conversion superheterodyne
 Sensitivity - Sensibilité - Gevoeligheid: AM/FM: 0.2 μ V for 10 dB S/N (typical)
 SSB: 0.14 μ V for 10 dB S/N (typical)
 Selectivity - Sélectivité - Selectiviteit: AM/FM: 6 kHz at 6 dB down
 SSB: 2 kHz at 6 dB down
 Adjacent channel selectivity: > 80 dB
 Audio output - Puiss. de sortie BF - LF uitgangsvermogen: > 2.5 W for 8 Ohms
 Squelch range - Réglage du silencieux: 0.4 μ V - 250 μ V
 IM freq. - Fréq. interméd. - Middenfrequentie: AM: 10.695 MHz - 455 kHz
 SSB: 10.695 MHz
 Spurious - Rejection des signaux indésirables: > 50 dB
 Clarifier range: \pm 800 Hz
 Tune range: \pm 5.5 kHz
 Intercept point - Insensibilité à l'intermodulation - Intermodulatievasth.: -3 dBm

JUMBO 3

SPECIFICATIONS - CARACTERISTIQUES - KENMERKEN

GENERAL - ALGEMEEN

Channels - Canaux - Kanalen: 227
 Operation mode: AM, FM, USB, LSB, CW
 Power - Aliment. - Voeding: 13.8 VDC
 Freq.: 26.055 - 28.315 MHz
 Other bands for commercial and amateur use available. Livrable avec fréquence amateur ou commerciale. Leverbaar met amateur of commerciële frequenties.
 Ant. impedance: 50 Ohms
 Dimensions - Afmetingen: 420 x 145 x 300 mm
 Weight - Poids - Gewicht: 8.5 kg.

TRANSMITTER - EMETTEUR - ZENDER

RF power output - Puiss. de sortie HF - HF uitgangsvermogen: AM: 8 W - 4 W - 0.5 W
 FM: 8 W - 4 W - 0.5 W
 SSB: 20 W - 12 W - 1 W
 Freq. tolerance: < 0.005 %
 Modulation - Modulatie: 100 % AM - 1.5 kHz FM (limited)

RECEIVER - RECEPTEUR - ONTVANGER

Receiving syst. - Syst. de réception - Ontvangstysyst.: AM/FM dual conversion superheterodyne
 SSB: single conversion superheterodyne
 Sensitivity - Sensibilité - Gevoeligheid: AM/FM: 0.2 μ V for 10 dB S/N (typical)
 SSB: 0.14 μ V for 10 dB S/N (typical)
 Selectivity - Sélectivité - Selectiviteit: AM/FM: 6 kHz at 6 dB down
 SSB: 2 kHz at 6 dB down
 Adjacent channel selectivity: > 80 dB
 Audio Output - Puiss. de sortie BF - LF uitgangsvermogen: > 2.5 W for 8 Ohms
 Squelch range - Réglage du silencieux: 0.4 μ V - 250 μ V
 IM freq. - Fréq. interm. - Middenfrequentie: AM: 10.965 MHz - 455 kHz
 SSB: 10.695 MHz
 Spurious - Rejection des signaux indésirables: > 50 dB
 Clarifier range: \pm 800 Hz
 Tune range: \pm 5.5 kHz
 Intercept Point - Insensibilité à l'intermodulation - Intermodulatievasth.: -3 dBm

page 1

Product service information

Alignment procedure

Applicable to models:

HAM INTERNATIONAL

MULTIMODE-III

CONCORD-III

JUMBO-III

KYOCERA CORPORATION
April 1983

page 2

- 1 Applicable units use PC board with KYOCERA ID code PTBM133A4X.
- 2 Alignment shall be made under the following conditions:
 - temperature 25°C
 - humidity 65 %

Unless strict result of the alignment is required, alignment shall be made under a normal temperature of 10 to 35°C.

- 3 Power supply voltage shall be dc 13.8 V \pm 0.1 V unless otherwise noted.
- 4 Special care should be excersised to avoid static destruction of PLL IC.
- 5 Testing equipment required are the following:

Audio oscillator (two required for two-tone adjustment of modulation), sine wave 10 to 20,000 Hz.

VTVM, 0.1 mV and up.

RF VTVM, peak-to-peak scaled, with probe.

dc regulated power supply, dc 4A and greater, with current meter.

Frequency counter, high sensitivity and input Z, 0 to 40 MHz.

Synchroscope, high sensitivity and input Z, 0 to 100 MHz.

RF power meter, thermo-coupled, 50 ohm, 50 W, 100 kHz to 50 MHz.

Standard signal generator, unbalanced 50 ohm, 1 kHz/400 Hz audio for 0 to 100 % modulation, FM modulator built in.

Speaker dummy load, 8 ohm, 50 W.

Circuit tester, 20 kohm/dc or greater.

Pulse generator, 0 to 500 Hz variable, duty 50 % or variable, 10 msec or less triggering, 0 to 1 V variable output.

Linear detector.

PLL synthesizer adjustment

Testing equipment hook-up.

Apply 13.8 V dc ± 0.1 V. Connect 1:10 probe to scope input. Connect frequency counter to the output of scope. Use 12 V dc scale on tester. Proceed as follows.

Reference frequency 10.240 MHz.

Turn unit power on. Set CB-PA switch to CB. Connect probe from synchroscope (see above) to #3 terminal of PLL IC PLL-02. Check frequency counter reads 10.240 MHz ± 200 Hz.

Off-set frequency 10.695 MHz.

Connect the probe from synchroscope to TP3. Select USB mode. Adjust CT7 for 10.695 MHz $\pm 100/-0$ Hz. Select LSB mode. Adjust CT8 for 10.692 MHz $\pm 0/-100$ Hz.

Band off-set frequency adjustment.

This adjustment is made to align the oscillating frequency of X3 - X6 corresponding to the band to be selected. Set unit to transmit mode. Rotate TUNE to center. For models equipped with CLARI OFF switch, set it to OFF.

For band A, adjust CT1 to adjust X3 (19.880 MHz) to 19.880 MHz ± 50 Hz;
for band B, adjust CT2 to adjust X4 (20.105 MHz) to 20.105 MHz ± 50 Hz;
for band C, refer to above for band B;
for band D, adjust CT3 to adjust X5 (20.330 MHz) to 20.330 MHz ± 50 Hz;
and
for band E, adjust CT4 to adjust X6 (20.555 MHz) to 20.555 MHz ± 50 Hz.

Select LSB mode. Select band B. Adjust CT5 so that X4 oscillates at 1.5 kHz lower than at USB mode. i.e. $20.105 - 0.0015 = 20.1035$ MHz. Tolerance within ± 250 Hz is acceptable for all bands in LSB mode.

VCO.

Connect tester to TP2 (+). Select band E, channel 40. Rotate core provided on VCO module for 0.6 V ± 0.1 V. Select band A, channel 80. Check for Vdd - 0.3 V or less.

Transmitter

Testing equipment hook-up.

Apply 13.8 V dc ± 0.1 V. Connect audio oscillator, adjusted to provide 1 kHz or 2.4 kHz 10 mV audio, to mic input of the unit. Connect power meter 15 W to the antenna output of the unit. Connect scope paralleled to it.

Preset.

If the alignment of the unit is evidently seemed to be upset, preset the following potentiometers, etc. as follows:

CT6, center.
T5, core top (but slightly into bobine).
RV2, center.
RV3, clockwise fully.
RV9, counterclockwise fully.

Preadjustment.

Set unit to transmit mode. Select USB mode. Select band E, channel 40. Apply test signal to mic input (see above). Adjust T1 - T6 and L11 (in that sequence) for peak reading on watt meter. Select band C, channel 1. Adjust T2 and T4 for maximum RF output.

Transmitter adjustment.

Select band E, channel 40.
Adjust T1 and T3 for maximum RF output.
Select band C, channel 1.
Adjust T2 and T4 for maximum RF output.
Repeat above for several times.
Perform the following:

- 1 - Compare the carrier level (on scope etc.) at channel 40 of band E with at channel 40 of band C. Adjust T2 (if necessary) so that both levels are equal as possible.
- 2 - Compare the carrier level at channel 1 of band E with at channel 1 of band C. Adjust T4 (if necessary) so that both levels are equal as possible.
- 3 - Compare the carrier level at channel 40 of band A with at channel 40 of band B. Adjust CT6 (if necessary) so that both levels are equal as possible.

Note Use RV9 to keep the RF output as low as 2 or 3 W during the above procedure.

Carrier leakage.

Select LSB mode. Remove mic test audio. Adjust RV5 for minimum RF output (leakage). Apply test mic audio. The difference between the conditions that with or without mic audio shall be more than 40 dB. Select USB mode. Check the same.

page 5

Final RF power stage.

Apply test mic audio. Select USB mode. Rotate RV3 fully clockwise. Rotate RV9 fully counterclockwise. Select band E, channel 40. Adjust T5 and L11 for maximum RF output.

SSB RF power.

Select USB mode. Apply 2.4 kHz 10 mV and 500 Hz audio to mic input. (The level of 500 Hz audio should be adjusted to such level that allows the following display at the transmitter output:

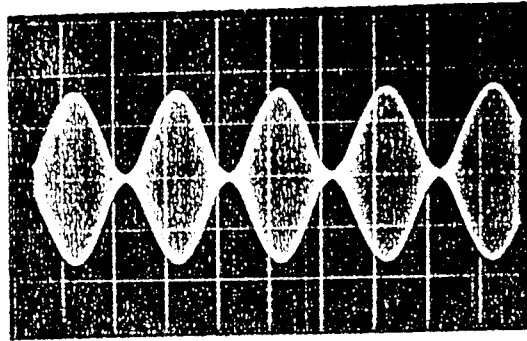

20V
0.5 ms

Adjust RV9 and RV3 for the rated RF power output.

Note RV9 should be preset to a 2 or 3 degree counterclockwise from its center position, the RF power output finally adjusted by RV3.

For models with provision of LO-HI RF power selection switch, preset RV9 as above and adjust RV3 with low RF power setting. The high (or middle) power adjusted automatically.

Bias adjustment.

Adjust RV2 so that RF output display causes no crossover.

Important. Do not rotate RV2 too far. Avoid over current.

AM (FM) RF power.

Adjust RV11 for the rated RF power.

AM modulation.

Adjust RV12 for more than 90 % modulation.

RF power meter (in unit).

Adjust RV4 so that the input meter indicates the same as discrete RF power meter.

FM deviation.

Select FM mode. Connect linear detector to the antenna output.

Apply 1.25 kHz 10 mV audio to mic input. Select the channel on which the deviation is lowest (e.g. channel 80, band A).

Adjust RV1 for 1.5 kHz deviation.

Note. Deviation should be more than 1.5 kHz (up to 3 kHz if no distortion occurs) for all channels and bands.

page 6

SWR (standing wave ratio)

For models with provision of SWR circuit only:

Select AM mode, transmitting mode. Connect a 100 ohm (10 W) dummy load to the antenna output. Rotate CALIBRATE control on unit front panel so that the SWR meter (in-unit) indicates 'SET' mark on the scale. Set CAL-SWR switch to SWR. Rotate potentiometer on SWR circuit PC board so that the SWR meter indicates '2'.

AWI (antenna warning indicator)

For models with provision of AWI circuit only:

Select AM mode, transmitting mode. Connect a 300 ohm (10 W) dummy load to the ante-na output. Apply 16.0 V ± 0.1 V power to the unit. Adjust potentiometer on AWI PC board so that the AWI indicator lights up faintly. Apply normal power voltage (13.8 V dc). Check AWI indicator turns off. Check AWI indicator lights up with antenna open or shorted. The AWI indicator should light with power supply voltage as low as 10.5 V.

Receiver alignment

SSB AGC

Select USB mode. Open antenna input. Rotate RF GAIN control fully clockwise (maximum sensitivity). Connect tester to #19 terminal on the main PC board. Adjust RV6 for 2.1 V \pm 0.1 V.

Select LSB mode. Check tester shows 2.1 V \pm 0.3 V.

Select AM mode. Check tester shows 1.8 to 2.3 V.

AM sensitivity

Select AM mode. Apply signal generator output to the antenna input, 1 kHz audio for 30 % modulation. Use attenuator on the generator to keep the procedure made easy and adjust T8 to T14 for maximum audio output at speaker output.

Note. The audio output level should be approximately 1.5 V during the alignment.

Rotate T9 a turn clockwise. Compare output level at the lowest frequency channel with at highest frequency channel. Use T10 so that both levels are equal as possible.

FM sensitivity

Select FM mode. Apply 1 microV antenna input, deviation 1.5 kHz. Adjust T15 for maximum audio output.

SSB sensitivity

Select USB mode. Apply 0.5 microV, no modulation to the antenna input. Rotate CLARIFIER control on the unit (or adjust the signal generator) so that 1 kHz audio is output from the unit. Adjust T7 for maximum output.

S-meter

AM - Apply 40 dB (100 micro-V) antenna input. Adjust RV8 for 'S9' on the S meter (in-unit).

SSB - Use same procedure as above except adjusting RV7.

SQUELCH.

Select AM mode. Apply 48 dB (approx. 300 microV) antenna input. Rotate SQUELCH control fully clockwise. Adjust RV10 so that audio just goes off. The squelch opens and closes with 40 to 56 dB antenna input for all modes.

RF GAIN.

Select AM mode. Adjust signal generator output for S/N 10 dB. Rotate RF GAIN fully clockwise (or set DX-LOC switch to DX if applicable). Adjust VOLUME control so that approx. 2 V audio is achieved. Rotate RF GAIN fully counterclockwise (or set DX-LOC switch to LOC if applicable). Increase signal generator output so that 2V audio is output. The difference between both conditions of generator output level should be 15 to 35 dB.

NB (noise blanker)

Use distributing device that allows both the signal generator output and the pulse generator output simultaneously to the antenna input. Adjust signal generator to 1 microV and pulse generator to 100 Hz, 1 microS, 500 mV p-p. S/N should be improved 7 dB or more when NB is on.

NEGATIVE CHANNEL				POSITIVE CHANNEL				HIGH	
CHANNEL NO.	FREQ. (MHZ)	CHANNEL NO.	FREQ. (MHZ)	CHANNEL NO.	FREQ. (MHZ)	CHANNEL NO.	FREQ. (MHZ)	CHANNEL NO.	FREQ. (MHZ)
41	26.505	1	26.955	1	26.965	41	27.415	1	27.865
42	" .495	2	" .945	2	" .975	42	" .425	2	" .875
43	" .485	3	" .935	3	" .985	43	" .435	3	" .885
44	" .465	4	" .915	4	27.005	44	" .455	4	" .905
45	" .455	5	" .905	5	" .015	45	" .465	5	" .915
46	" .445	6	" .895	6	" .025	46	" .475	6	" .925
47	" .435	7	" .885	7	" .035	47	" .485	7	" .935
48	" .415	8	" .865	8	" .055	48	" .505	8	" .955
49	" .405	9	" .855	9	" .065	49	" .515	9	" .965
50	" .395	10	" .845	10	" .075	50	" .525	10	" .975
51	" .385	11	" .835	11	" .085	51	" .535	11	" .985
52	" .365	12	" .815	12	" .105	52	" .555	12	28.005
53	" .355	13	" .805	13	" .115	53	" .565	13	" .015
54	" .345	14	" .795	14	" .125	54	" .575	14	" .025
55	" .335	15	" .785	15	" .135	55	" .585	15	" .035
56	" .315	16	" .765	16	" .155	56	" .605	16	" .055
57	" .305	17	" .755	17	" .165	57	" .615	17	" .065
58	" .295	18	" .745	18	" .175	58	" .625	18	" .075
59	" .285	19	" .735	19	" .185	59	" .635	19	" .085
60	" .265	20	" .715	20	" .205	60	" .655	20	" .105
61	" .255	21	" .705	21	" .215	61	" .665	21	" .115
62	" .245	22	" .695	22	" .225	62	" .675	22	" .125
63	" .215	23	" .665	23	" .255	63	" .705	23	" .155
64	" .235	24	" .685	24	" .235	64	" .685	24	" .135
65	" .225	25	" .675	25	" .245	65	" .695	25	" .145
66	" .205	26	" .655	26	" .265	66	" .715	26	" .165
67	" .195	27	" .645	27	" .275	67	" .725	27	" .175
68	" .185	28	" .635	28	" .285	68	" .735	28	" .185
69	" .175	29	" .625	29	" .295	69	" .745	29	" .195
70	" .165	30	" .615	30	" .305	70	" .755	30	" .205
71	" .155	31	" .605	31	" .315	71	" .765	31	" .215
72	" .145	32	" .595	32	" .325	72	" .775	32	" .225
73	" .135	33	" .585	33	" .335	73	" .785	33	" .235
74	" .125	34	" .575	34	" .345	74	" .795	34	" .245
75	" .115	35	" .565	35	" .355	75	" .805	35	" .255
76	" .105	36	" .555	36	" .365	76	" .815	36	" .265
77	" .095	37	" .545	37	" .375	77	" .825	37	" .275
78	" .085	38	" .535	38	" .385	78	" .835	38	" .285
79	" .075	39	" .525	39	" .395	79	" .845	39	" .295
80	" .065	40	" .515	40	" .405	80	" .855	40	" .305

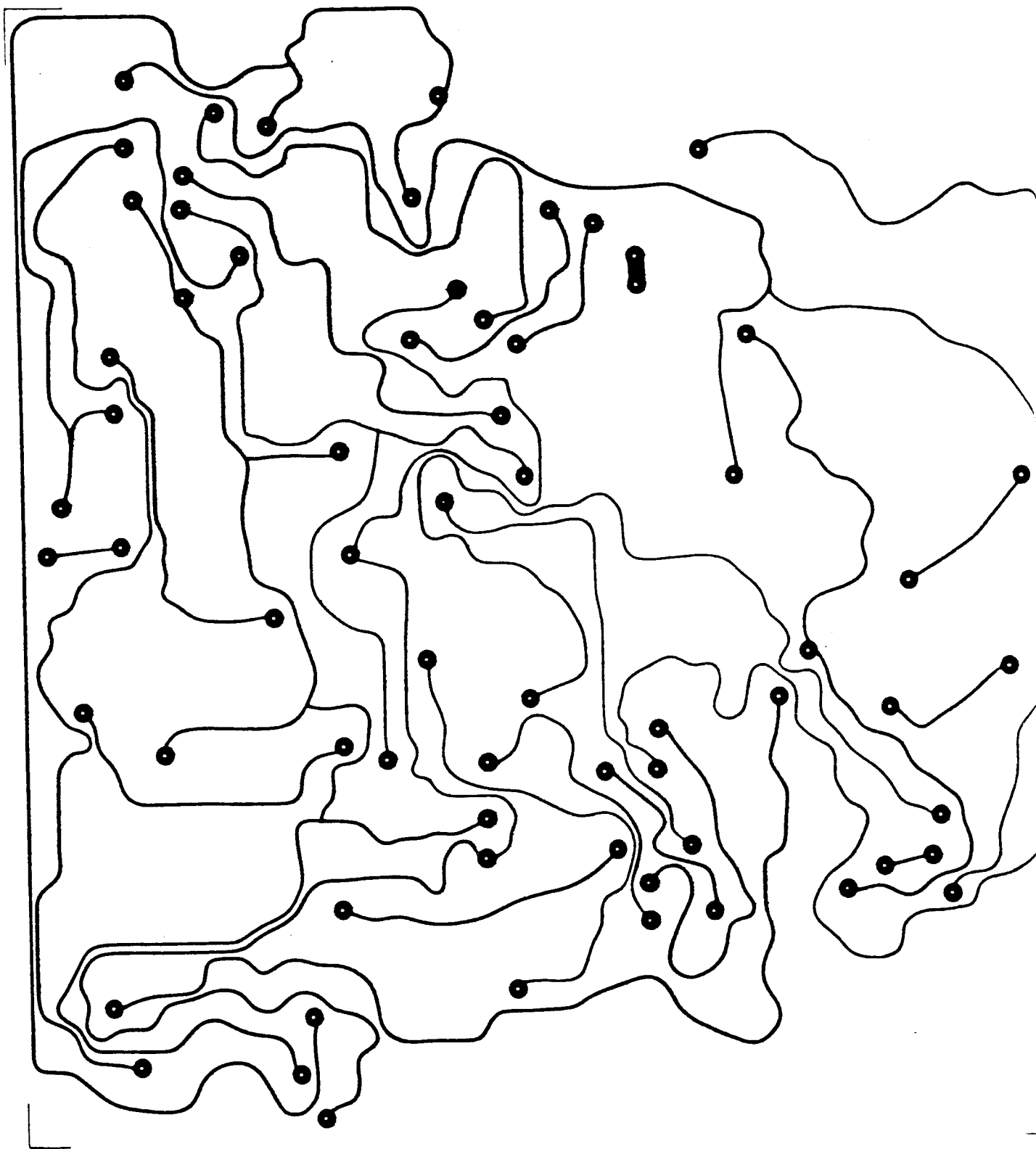

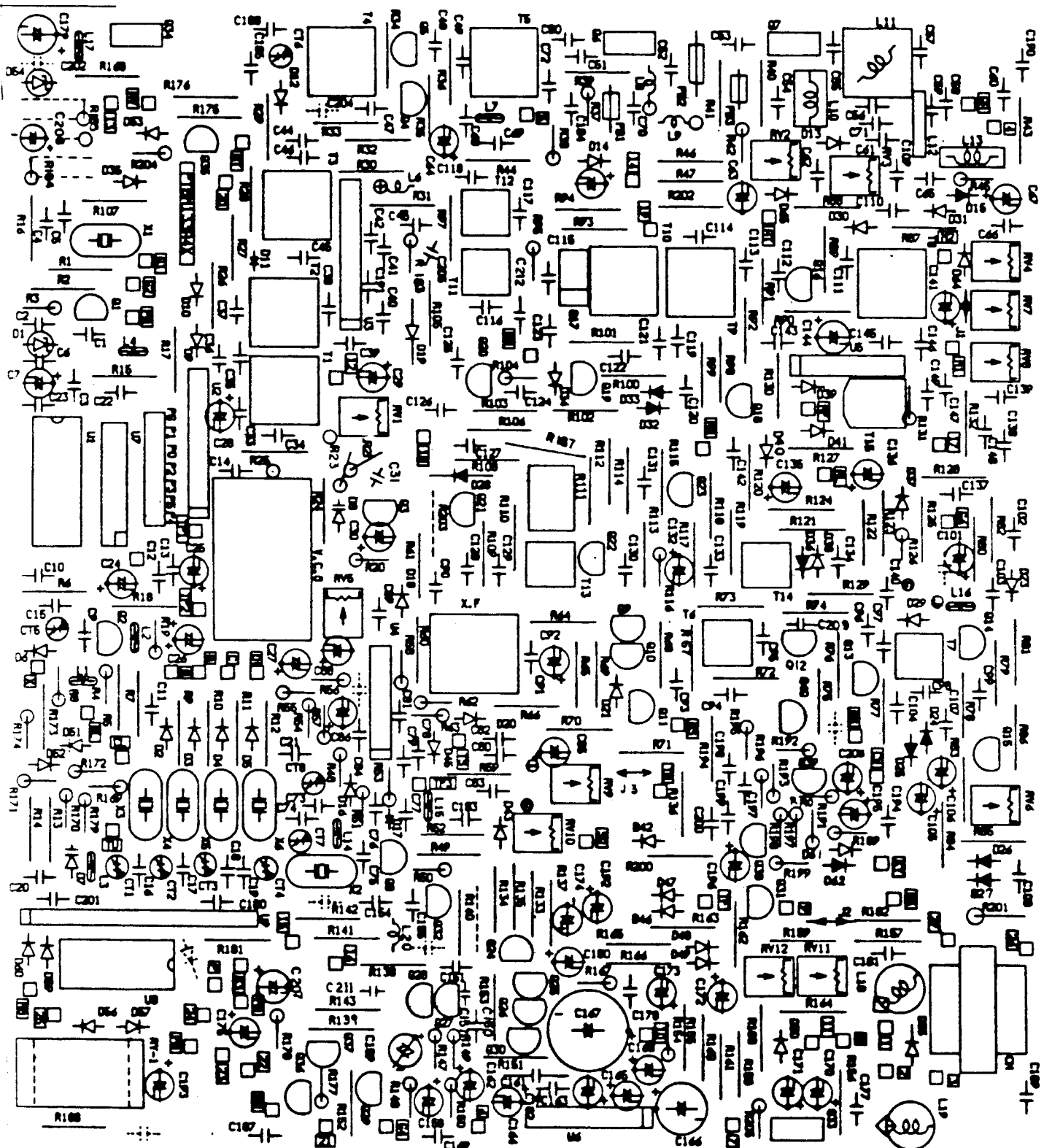

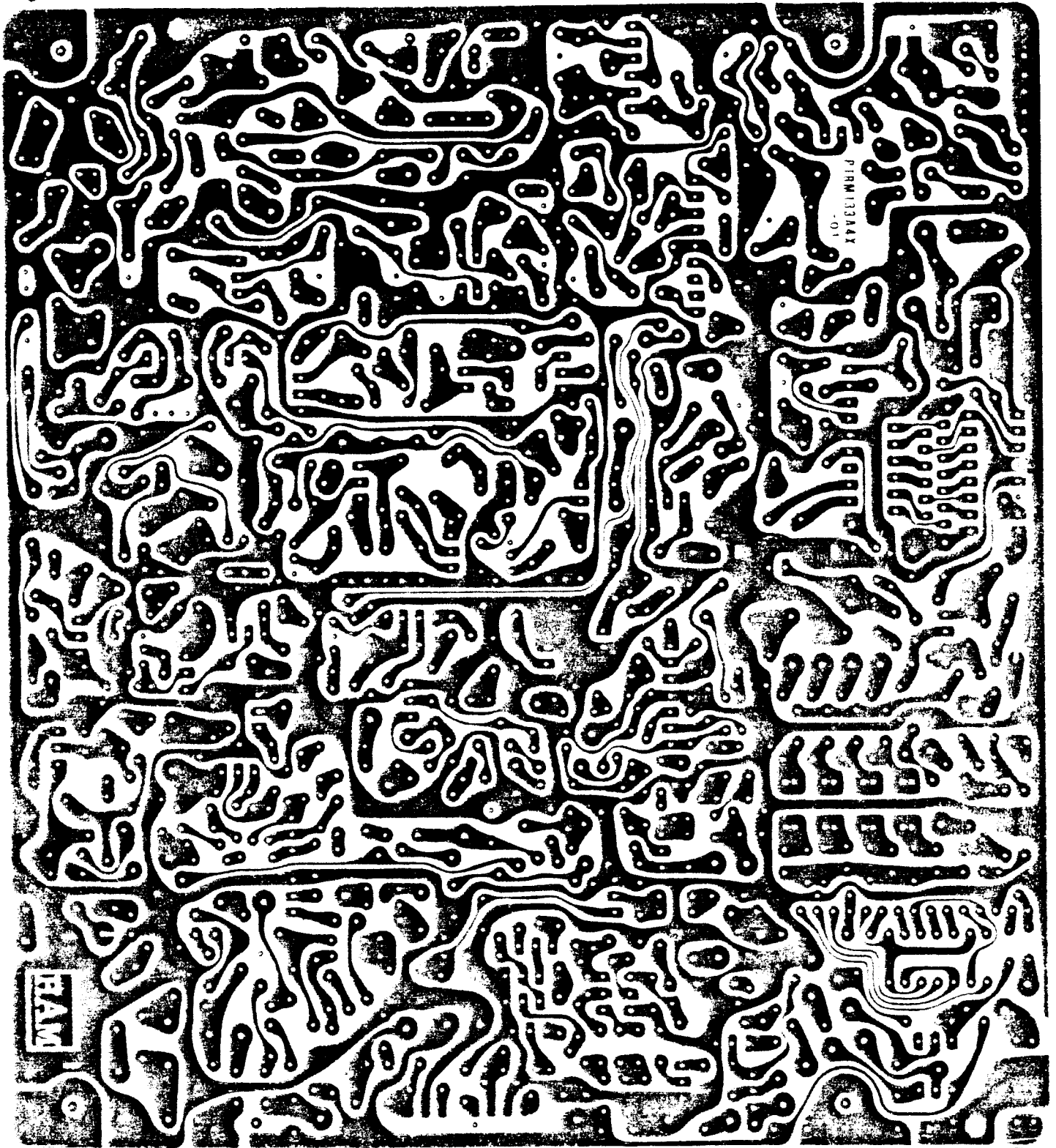

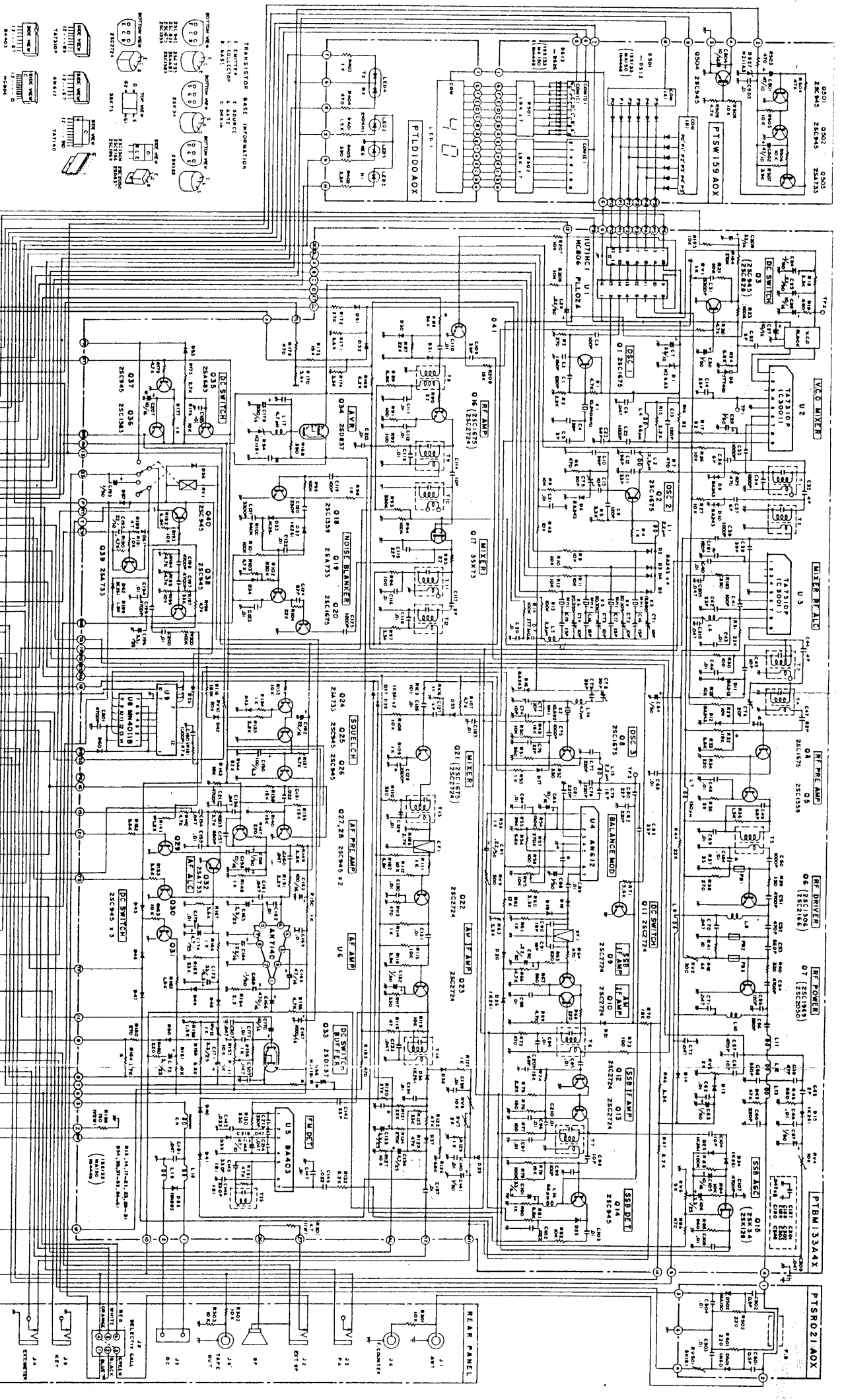

NOTE:
1. ALL VOLTAGES MEASURED FROM PC.
2. NO SIGNAL (LOCAL SIGNAL) AT THE
3. MEASUREMENT VALUES OBTAINED
4. IN EXCESS OF 20% OF VALUES
5. SHOULD BE CONSIDERED APPROXIMATE
6. ± 1% D.C. LOAD. (A.A. TX
7. ± 1% D.C. LOAD. (A.P. BOARD AND
8. ADJUSTED TYPICAL VALUE SHOWN)

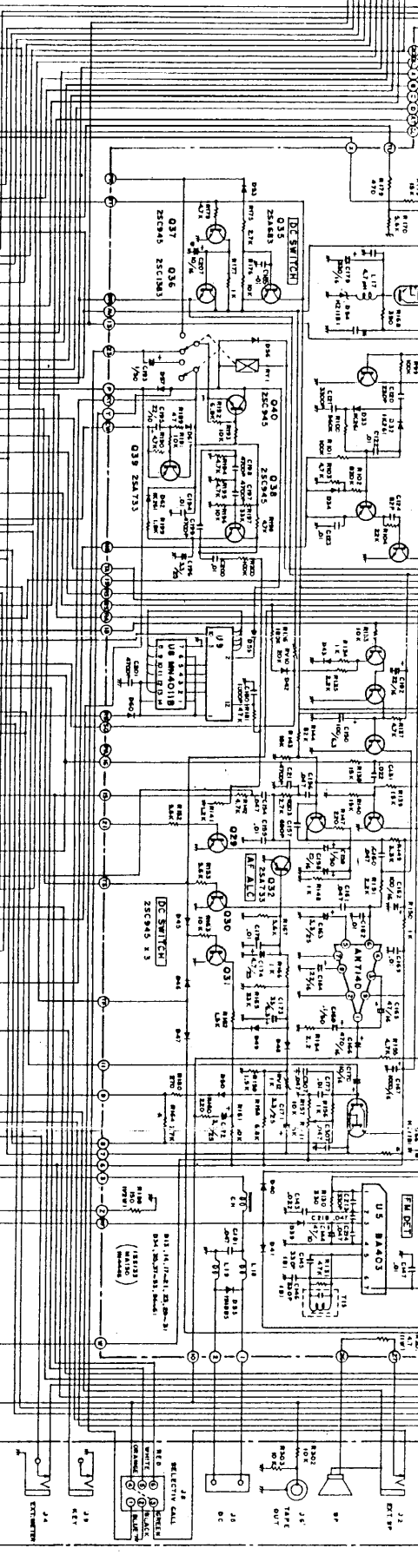
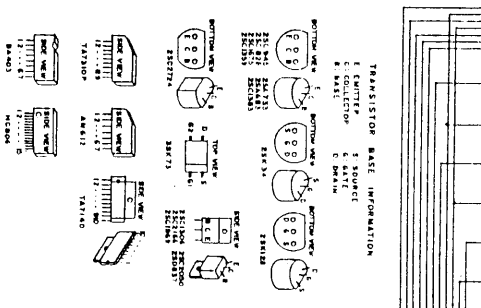

1782 3.3
41241 14574 4 8 8
SCHEMATIC DIA.
ASCO LCA 3 EX 43
MODEL
CONCORDE - 3
MAY 9 1972
1-72

ALL COMPONENTS OBTAINED FROM P.C. BOARD
 VALUES OBTAINED FROM SUPPLIER IF NOT SHOWN
 VALUES OBTAINED ARE IN EXCESS OF 20%
 VALUES SHOWN WITHIN BRACKET FOR
 C-13, D-13, E-13, F-13, G-13, H-13
 & CHASSIS GND. P.C. BOARD GND
 & ADJUSTED TYPICAL VALUE SHOWN

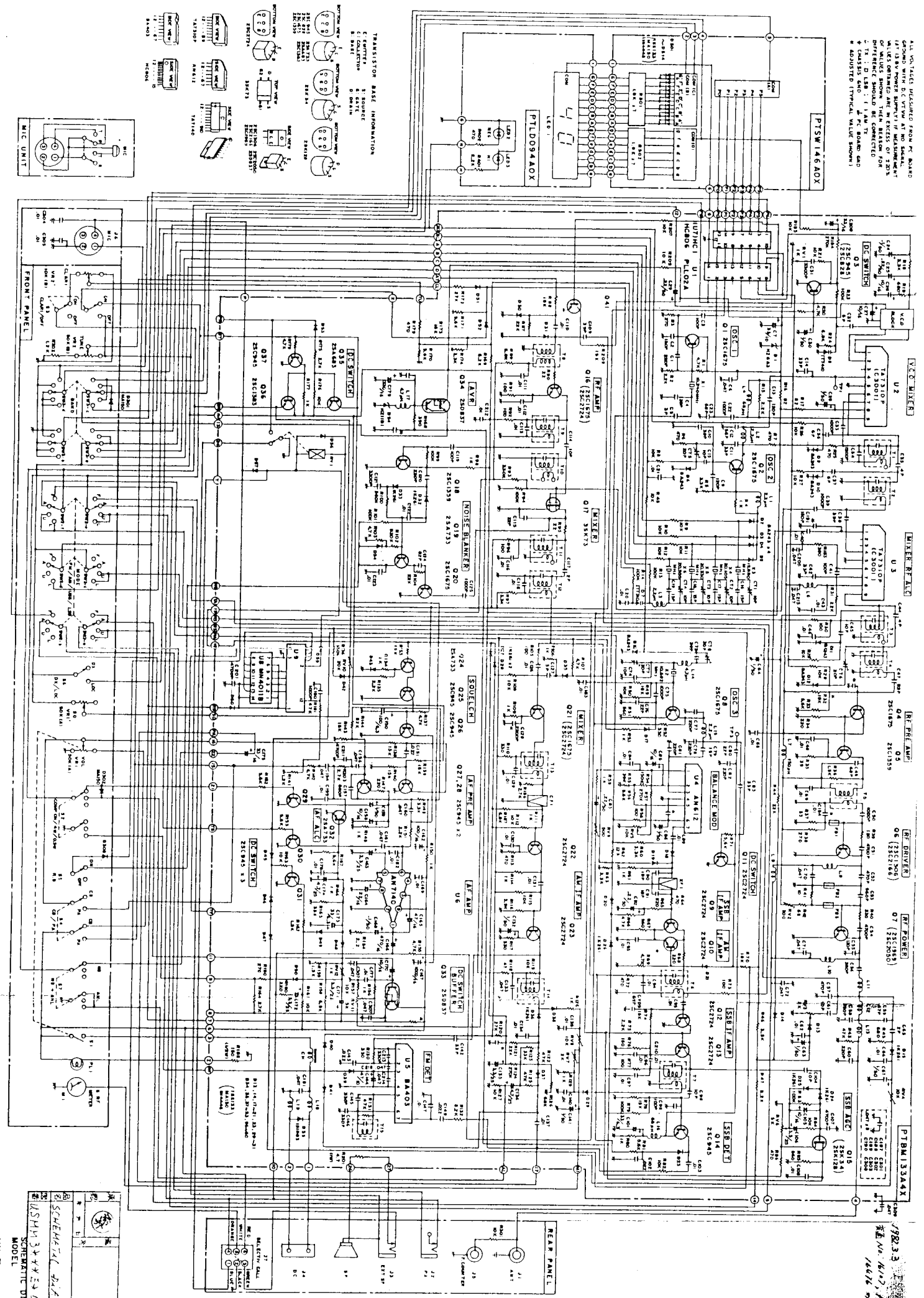

TRANSISTOR BASE INFORMATION
 C-EMITTER S-SOURCE
 D-COLLECTOR S-SOURCE
 E-BASE S-SOURCE

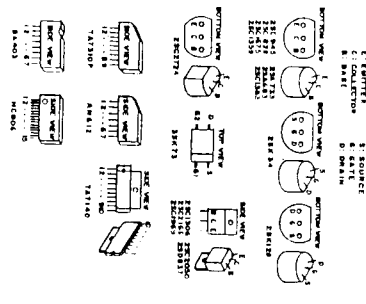
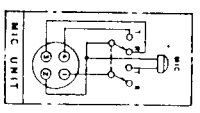

1982.3
 16616
 MULTI-MODE - II
 MODEL 3443A-02
 SCHEMATIC DIAGRAM
 SCHEMATIC DIAGRAM
 MULTI-MODE - II
 MODEL 3443A-02
 SCHEMATIC DIAGRAM

