

# **LUITON**<sup>®</sup>

## AM/FM CB RADIO

# LT-338



# **INSTRUCTION MANUAL**

With the present declaration, we certify that the following products:

## LUITON LT-338

Comply with all the technical regulations applicable to the above mentioned products in accordance with the EC Directives 2006/95/EC,2004/108/EC 99/5EC.

Type of product: AM/FM MP3 CB RADIO  
Details of applied standards: EN 60950-1+A11  
EN 301489-1/-13  
EN300433-1/--2  
EN 300135-1/--2

Manufacturer/Importer:  
Notified Body:  
Contact Reference:  
Ede,16-08-2023

### WARNING

Please install the antenna (connect to the location (B) in the back panel of the radio) and set the SWR (Standing Wave Ratio) before transmitting.

Otherwise it may result in destruction of the power amplifier, which is not covered by the guarantee.

### WELCOME TO USE

LT-338 is a Multi-norms and multi-function CB radio which provides you with top performance.

With the use of SMT technology to guarantee the best stability, reliability and unprecedented quality, LT338 is a new step in personal communication and is surely the best choice for professional users of CB radios. Moreover it adopts flash CPU in the radio, which makes LT-338 ready for future upgrading and functions expanding. To ensure that you use the radio to the fullest, please read this manual carefully before installing.

## TABLE OF CONTENTS

<b>INSTALLATION</b> .....	<b>4</b>
<input type="checkbox"/> Where And How To Mount Your Mobile CB Radio .....	4
<input type="checkbox"/> Antenna Installation.....	4
<input type="checkbox"/> Power Connection .....	5
<input type="checkbox"/> Basic Operations.....	6
<input type="checkbox"/> Adjustment Of SWR (Standing Wave Ratio).....	6
<b>HOW TO USE YOUR CB RADIO</b> .....	<b>7</b>
<input type="checkbox"/> Front panel .....	7
<input type="checkbox"/> Rear Panel .....	9
<input type="checkbox"/> Norm Selection.....	10
<input type="checkbox"/> Reset.....	10
<b>TECHNICAL CHARACTERISTICS</b> .....	<b>11</b>

## INSTALLATION

### □ Where And How To Mount Your Mobile CB Radio

- You should choose the most appropriate setting from a simple and practical point of view.
- Your CB radio should not interfere with the driver or the passengers.
- Remember to provide different wires for the passing and protection (e.g.: power, antenna, accessory cabling) so that they do not in any way interfere with the driving of vehicles.
- To install your equipment, use the cradle (H) and the self-tapping screws (E) provided (drilling diameter 4 mm). Take care not to damage the vehicle electrical system while drilling the dash board.
- Do not forget to insert the rubber joints (G) between the CB and its support as these have a shock-absorbing effect which permits gentle orientation and tightening of the set.
- Choose where to place the microphone support and remember that the microphone cord must stretch to the driver without interfering with the controls of the vehicle.
- As the transceiver has a frontal microphone socket, it can be set into the dash board. You will need to add external loud speaker to improve the sound quality of communications (connector ext. SP situated on the back panel (D)). Ask your dealer for advice on mounting your CB radio.

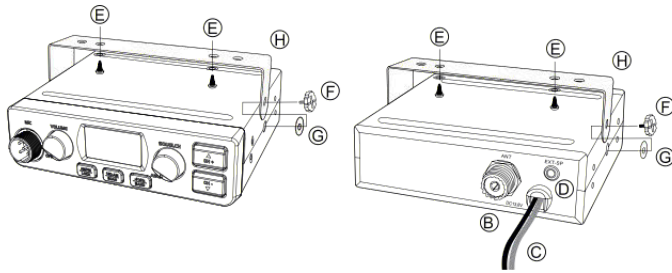

### □ Antenna Installation

- Choosing antenna
  - For CB radios, the longer the antenna, the better its results. Your dealer will help you with your choice of antenna.
- Mobile antenna
  - Must be fixed to the vehicle where there is a maximum of metallic surface (ground plane), away from windscreen mountings.
  - If you already have a radio-telephone antenna installed, the CB antenna should be higher than this.
  - There are two types of antenna: Pre-regulated antenna which should be used

on a good ground plane (e.g. car roof or lid of the boot), and adjustable antenna which offer a much larger frequency range and can be used on a smaller ground plane.

- For an antenna which must be fixed by drilling, you will need a good contact between the antenna and the ground plane. To obtain this, you should lightly scratch the surface where the screw and tightening star are to be placed.
- Be careful not to pinch or flatten the coaxial cable (as this runs the risk of break down and/or short circuiting).
- Connect the antenna to location (B).

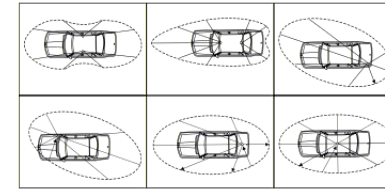

OUTPUT RADIUS PATTERNS

### c) Fixed antenna

A fixed antenna should be installed in a space as spacious as possible. If it is necessary for you to fix the antenna to a mast, you need to keep it as per the requirements of the laws in force (please turn to professional advice).

### □ Power Connection

This is protected against an inversion of polarities. However, before switching it on, you are advised to check all the connections. Your equipment must be supplied with a continued current of 12 volts (A). Today, most cars and lorries are negative earth. You can check this by making sure that the negative terminal of the battery is connected either to the engine block or to the chassis. If this is not the case, you should consult your dealer.

**WARNING:** Lorries generally have two batteries to supply a voltage of 24 volts, in which case it will be necessary to insert a 24/12 volt converter into the electrical circuit. The following connection steps should be carried out with the power cable disconnected from the set.

- Check whether the battery is of 12 volts.
- Locate the positive and negative terminals of the battery (+ is red and - is black). Should it be necessary to lengthen the power cable, please use the same or a superior type of cable.
- It is necessary to connect your CB to a permanent (+) and (-). We advise you to connect the power cable directly to the battery (as the connection of the CB cable to the wiring of the car-radio or other parts of the electrical circuit may, in some cases, increase the possibilities of interference).
- Connect the red wire (+) to the positive terminal of the battery and the black (-)

wire to the negative terminal of the battery.

e) Connect the power cable to your CB radio.

**WARNING:** Never replace the original fuse (5A) by one of a different value.

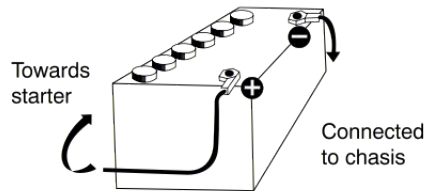

### Basic Operations

- a) Connect the microphone.
- b) Check the antenna connections
- c) Turn the set on by turning the volume knob clockwise.
- d) Turn the squelch knob to minimum(Full anti-clockwise).
- e) Adjust the volume to a comfortable level.
- f) Go to channel 20@EC by using either the [CH+▲] or [CH-▼] key

### Adjustment Of SWR (Standing Wave Ratio)

**WARNING:** This must be carried out when you use your CB radio for the first time (and whenever you re-position your antenna). The adjustment must be carried out in an obstacle-free area.

**Adjustment should be operated with external SWR meter.**

- a) To connect the SWR meter
  - Connect the SWR meter between the CB radio and the antenna as close as possible to the CB radio (use a maximum of 40cm cable)
- b) To adjust the SWR meter
  - Set the CB to channel 20@EC band in FM
  - Put the switch on the SWR meter to position CAL or FWD
  - Press the <<Push-To-Talk>> switch on the microphone to transmit.
  - Bring the index needle to [CH-▼] by using the calibration key
  - Change the switch to position SWR (reading of the SWR level)
  - The reading on the meter should be as near as possible to 1. If this is not the case, re-adjust your antenna to obtain a reading as close as possible to 1. (An SWR reading between 1 and 1.8 is acceptable).

## HOW TO USE YOUR CB RADIO

### Front panel

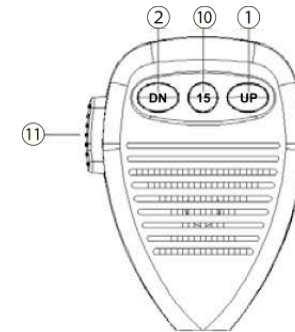
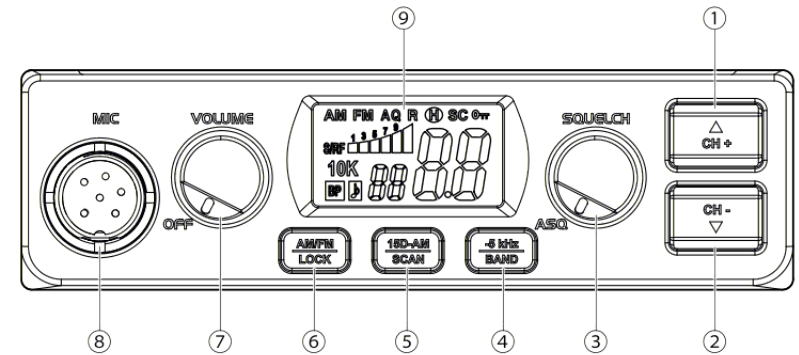

#### ① [CH-] key (DN key on the microphone)

Channel down; selected channel downward.

#### ② [CH+] key (UP key on the microphone)

Channel up; selected channel upward

All channels can be selected by channel selector keys ⑤ or ⑥. The selected channel is displayed on the LCD. In communication both transceivers (the receiving and transmitting party) need to be in the same channel and under same modulation type.

#### ③ SQUELCH

**Manual Squelch:** Turn the Squelch knob ② clockwise to the exact point where all background noise disappears. Please note that this control is fine regulation, if you set this Squelch control to the maximum (fully clockwise), the radio can only receive the strongest signal.

**ASQ:** Turn the Squelch knob ② anti-clockwise until LCD display AQ, The radio enter ASQ function.

#### ④ -5 kHz | BAND

**-5 kHz:** Press ⑧ into E/P band selection, E band is 5K band, P band is 10K band.

**BAND:** Hold & Press ⑧ into channel selection.

#### ⑤ CH9/19 (15D-AM | SCAN)

It contains the priority channels 9 and 19, press the key ⑨ [CH9/19] once to select priority channel 9, press the key ⑦ [CH9/19] again to set priority channel 19.

**SCAN:** Press the key ⑨ [SCAN] to enable the SCAN function. Before enabling the SCAN function, firstly turn the SQ control clockwise till the background noise is cut out, Then press the key ⑨ [SCAN], radio will automatically scan all channels and the SC icon will appear on the LCD.

When a signal is detected on a channel, scanning stops on this channel. You can receive the calling, and also can transmit on this channel by pressing PTT key. If there is no transmission or detected signal on that channel within 5 seconds, radio will start scanning again. To exit the SCAN function, press the SC key or the PTT key.

#### ⑥ AM/FM | LOCK

Modulation Mode selection: This key ⑦ [AM/FM] allows selecting the AM or FM modulation. Your modulation mode has to correspond to the one of your correspondent.

With the version Full Multi Norm in the norm UK, you can switch between the EU band and the UK band, which is indicated by symbol "EU" or "UK", by pressing the key ⑦ [AM/FM]. The CB band EU consists of the 40 CEPT channels.

The CB band UK consists of 40 channels starting from 27.60125 MHz to 27.99125 MHz.

#### ⑦ OFF/VOLUME

- To turn the set on, turn the knob ① clockwise.
- To increase the sound level, turn the same knob further clockwise.

#### ⑧ Microphone Jack

Connect a six pin microphone supplied with radio.

#### ⑨ LCD

Display for channel, TX/RX status, mode, H/L power, etc.

#### ⑩ 15 (on the Microphone)

Press 15 keys to quickly enter the de 15 channel AM mode.

#### ⑪ PTT on the microphone

To transmit, press and hold the key ⑫ [PTT] and the TX icon will appear on the

LCD. For best quality, please speak normally at a distance of 2-4 inches.

Speaking too loudly will cause distortions and make the signal difficult to understand. On completion of the transmission release the PTT key and the radio will revert to receiving mode.

#### □ Rear Panel

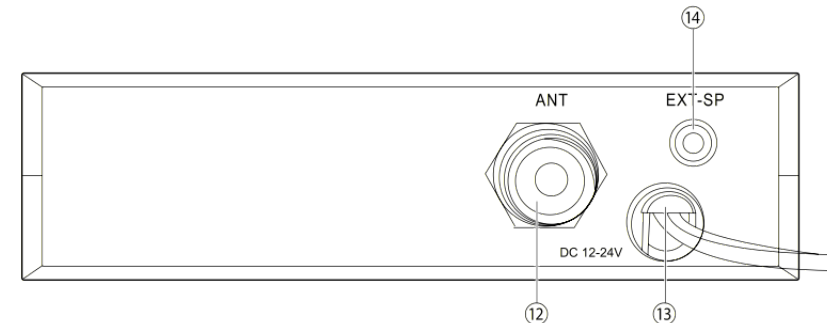

#### ⑫ ANT

Plug (PL-259) for connecting the antenna with an 50 Ohms coaxial cable.

#### ⑬ DC12-24V

12-24 V DC power cord with 5 A fuse.

#### ⑭ EXT-SP

The radio is equipped with a 3.5 mm jack socket at the rear panel to connect an external speaker of 4-8 ohm impedance. At 4 ohms the speaker load can be 4 watts. When the external speaker is connected, the internal speaker will be switched off.

## ❑ Norm Selection

The version Full Multi Norm can be set by the user to the following norms:

D	80 FM (26.565-27.405 MHz), 4W 40 AM (26.965-27.405 MHz), 1W
EU	40 FM (26.965-27.405 MHz), 4W 40 AM (26.965-27.405 MHz), 1W
EC	40 FM (26.965-27.405 MHz), 4W
UK	40 FM (27.60125-27.99125 MHz), 4W 40 FM (26.965-27.405 MHz), 4W
PL	40 FM (26.960-27.400 MHz), 4W 40 AM (26.960-27.400 MHz), 4W
E	40 FM (26.965-27.405 MHz), 4W 40 AM (26.965-27.405 MHz), 4W
US	40 AM (26.965-27.405 MHz), 4W
RU	25.615-30.105/25.615-28.305 MHz
PO	25.610-30.100/25.610-28.300 MHz

To change current norm, please hold the key ⑦ [AM/FM] while turning the radio on. In the display, the symbol of the current norm appears, please select the norm by pressing the channel selector key ⑤ or ⑥. To verify your selection, turn the radio off and on again, the radio automatically returns to the selected operation mode.

**NOTE:** The norm is internally set to 40 channels FM, 4 Watts only

## ❑ Reset

Hold key ⑨ to power on the radio, it will reset and all channel data will resume factory default setting.

## TECHNICAL CHARACTERISTICS

GENERAL	
Frequency ranges	25.610-30.105MHz
Modulation modes	AM/FM
Antenna impedance	50 Ohms
Power supply	12V-24V
Dimensions (in mm)	150×140×41mm
TRANSMISSION	
Carrier power	4W/8W
Frequency error	±300Hz
Emitted power in the adj channel	inferior to 20μW
Transmission interference	inferior to 4nW (-54dBm)
Audio response	300Hz to 3kHz in AM/FM
Microphone sensitivity	3mV
Maximum current	max 3A
Modulated signal distortion	inferior to 5%
RECEPTION	
Max sensitivity at 20dB sinad	0.8μV to 113 dB FM; 1.5μV to 103 dBm AM
Frequency response	300Hz to 3kHz in AM/FM
Adjacent channel selectivity	60dB
Maximum audio power	3W
Squelch sensitivity	Minimum 0.2μV,-120 dBm; Maximum 1mV,-47 dBm
Maximum current	0.3A nominal/1.2A maximum

***LUITON***<sup>®</sup>

***Bond Telecom Co. Ltd.***

***Website: [www.luiton.com](http://www.luiton.com)***